

ACCT		TOWNSHIP		PIN #		TAX CODES			
60912		14-PIGEON		8644-38-1942		F15			
SALE DATE	SALE PRICE	VALID	BOOK/PAGE	DATE APP	BY	PREVIOUS VALUE			
02/22/2006	0		659/432	01/20/2021	LFT	LAND 0			
NEIGHBORHOOD		LAND MODEL		ACRES		BUILDINGS			
14C001				3.8883		TOTAL 0			
MTHD	TYPE	ACR/ SQFT	RD	CODE / ADJUSTMENT	PUV	APPRAISED VALUE	DEFERRED	USE VALUE	EX
AC	CP	1.000	P			50,000			
AC	CR	2.890	P	FP-13,FW-13		27,300			

**GENERAL REMARKS**

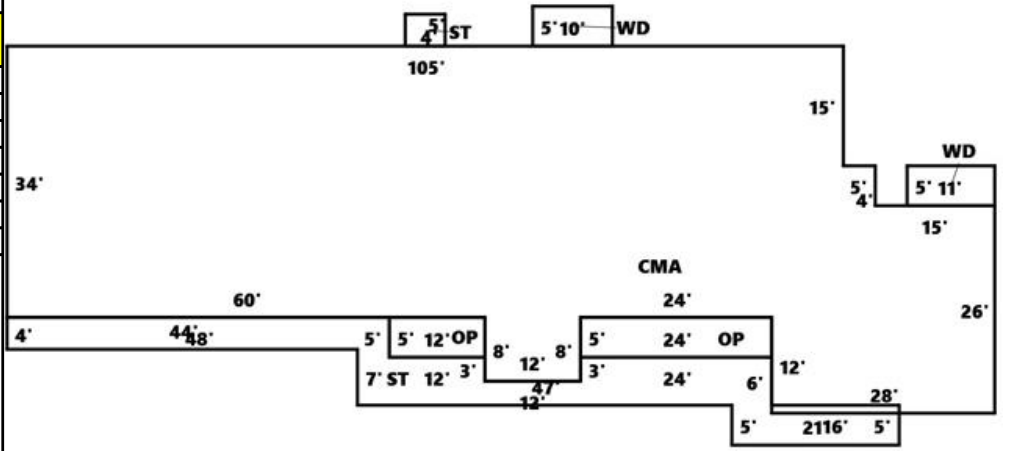

METHOD	C	DESCRIPTION	1.0/S/B	BUILDING DEPRECIATION					% COMPLETE	100	USE	RWI	TOTAL BUILDING VALUE	156,500
SECTIONS	7	REMARKS	JUKEBOX JUNCTION	PHYS		FUNC		FC	20	ECONOMIC	EC		25	
# ROOMS		FEATURES					REPLACEMENT VALUE					482,847		

TYPE	AREA	OCC	WL HGT	STO RIES	EXT WAL	BASE MENT	BSMT% FINSHD	RECRM% FINSHD	FUS	UUS	ATTIC	BED	BATH	FIREPLACE OPEN/STACK	HEAT	AIR	SPRNKLR	PERIMET R	GRAD E	YR BLT	EFF AGE	CDU	DESIG N	PHY DEP	FUNC DEP	MKT FAC	REP VALUE	DEP TAX VALUE
CMA	4,288	CM	8	1.00	EP	1905									P			356	C	1970	1970	G		20		469,933	152,300	
OP	60			1.00																							1,536	500
OP	120			1.00																							2,766	900
ST	577			1.00																							6,347	2,100
ST	20			1.00																							327	100
WD	50			1.00																							923	300
WD	55			1.00																							1,015	300

MTHD	TYPE	% CMLPT	COUNT	WIDTH	LNGLTH	AREA	STORIES	EXT WALL	AIR	HEAT	GRADE	YR BLT	EFF AGE	CDU	FUNC DEP	ECONOMIC DEPR.	TAX VALUE	REMARKS
O	PVA					27800	1.00				C	1991	1991	F			27,800	ASPHALT PAVING

# Haywood County - Property Record Card

APPRAISED VALUE SUMMARY		USE VALUE SUMMARY		TOTAL TAX VALUE
LAND	BUILDING	LAND	BUILDING	261,600
77,300	184,300			